

Multiplexer Circuit

ME218B 2017, Team 4

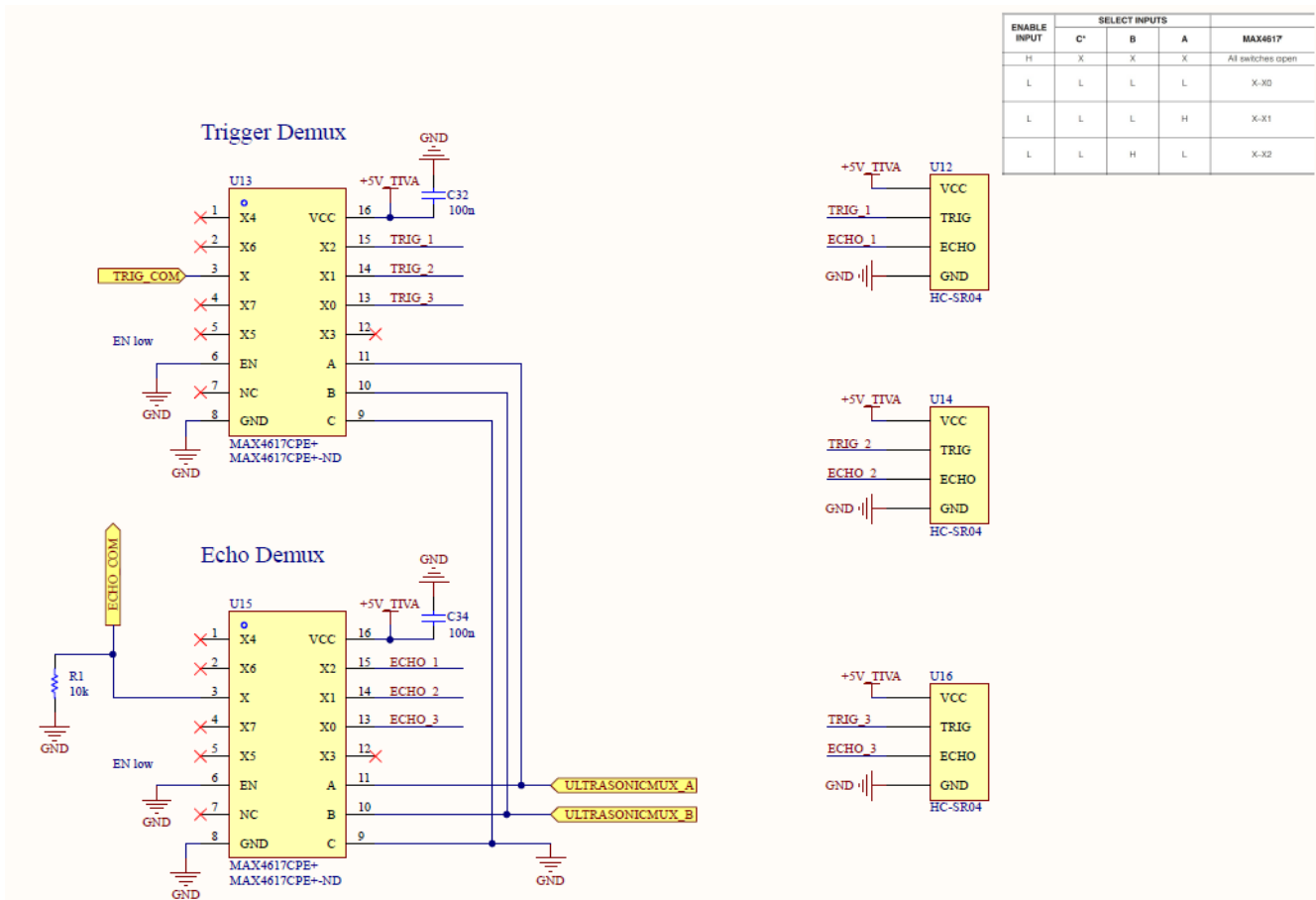

Figure 1: Multiplexer circuit in Altium

Two MAX4617 multiplexers were used to connect three HC-SR04 ultrasonic sensors to the Tiva. The on resistance of the mux is at most 10Ω , which did not pose a problem when interfacing the sensors to the Tiva. The switch on/off times are at most $18ns$ when run at $5V$, which is negligible for ultrasonic sensor timing. For reference, it takes 30 microseconds for sound to traverse 1 cm (roughly the resolution of the Hc-SR04) in air.